

THE VERSATILITY AND PERFORMANCE OF A SAMURAI.

Cutting and trimming doesn't always have to be a chore. Cutting hedges, brush and small trees is as easy as hopping on any tractor or skid steer with the Samurai, a hydraulic powered cutter that easily attaches to the loader bucket.

The Samurai offers the versatility to be positioned vertically, horizontally or any angle in between, allowing you to cut under fence lines, along roadways, ditches or trees and hedges.

A high torque hydraulic motor powers an oscillating cam connecting two cutting blades which enables the Samurai to cut through the thickest of material.

If you add it all up, the Samurai is an innovative and cost effective solution to the challenges of maintaining overgrowth. It's one of the most versatile pieces of equipment you will ever own!



Cuts up to 1 1/2 inches in diameter.

Dual hardened steel sickle sections provide an effective clean cut from both sides preventing tearing and damage to the branch.

Trim tree lines with ease.



Hydraulic powered cutter with universal mounting bracket, installs within minutes without any modifications to the loader bucket.

Extended reach allows for easy manoeuvrability for cutting underneath electrical fence lines.



The Universal Bracket



Cut at any angle with the Samurai's easy-to-use Universal Bracket.

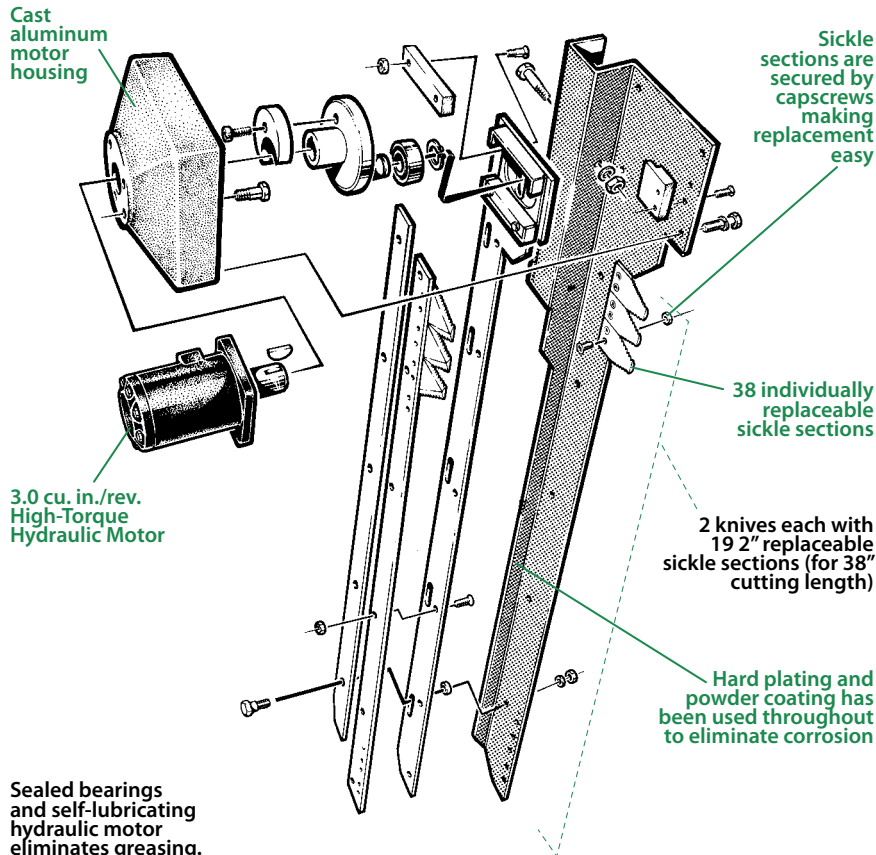

We use the following hydraulic motors:

Charlyn (H) Series - #101-1001

Danfoss - #151-2121

Ross - #MK021310AAAB

SAMURAI SPECIFICATIONS:	
Hydraulic motor	3.0 cu. in/rev. High Torque
Hydraulic oil flow requirements	3.3 gal/min at operating speed of 250 rpm
Hydraulic pressure	Less than 500 psi during normal operation
Hose requirements (not included)	100 RI ½ diameter ½ NPT to 7/8-14 JIC 37 100 RI ½ diameter ½ NPT to 7/8-14 JIC SW 10 female
Overall length	48 inches
Overall width	10.35 inches
Overall height	9.81 inches
Cutter weight	50 lbs
Bracket weight	15 lbs
Cutting length	38 Inches

SAFETY IS NO ACCIDENT. Canadian Agri Technologies Inc. reminds you that before operating any piece of equipment be sure to read and understand the operators manual. This manual should be kept with the machine at all times. Additionally, be sure all safety decals supplied are affixed in a prominent position on the operating equipment. Canadian Agri Technologies Inc. reserves the right to make changes in specifications shown herein and add improvements at any time without notice or obligation.

PRINTED IN CANADA.

FEATURES AND BENEFITS

Adaptable to multiple equipment from tractors to skids steers.

Mounting bracket mounts to any size bucket for versatility.

Installation and removal in a manner of minutes with simple hand tools.

Minimal hydraulic flow requirements allowing for use on almost any equipment.

High torque hydraulics cuts up to 1½" material.

Trimming fall into bucket for easy clean up.

38" cutting bar for wide cutting swath.

Horizontal / Vertical positioning for universal versatility.

Maintenance free for ease of use.

USED BY:

Farmers/Ranchers
Forestry Service
Highway Maintenance Dept.
Municipalities
Utility Companies
Landscapers
Golf Courses
Rental Centers
Snowmobile Associations
Tree Farms
Arborists



47 Halparin Drive
Winnipeg, MB
R3X 1Z9
Ph: (204) 992-2484
Fax: (204) 237-0552

Toll Free: 1-866-792-8437

www.cutthat.com

DEALER